

pennekamp ▶



—  
3-Axis Servo Stacker LS 750 / 3-AS

# Lehr stackers

## 3-Axis Servo Stacker LS 750 / 3-AS

The lehr stacker is designed to transfer glass ware in rows from the cross conveyor across the transfer plates onto the lehr mesh belt. This reliable lehr stacker has been designed for the operation with high capacity IS machines and production lines speeds of up to 750 BPM, as well as for extremely critical, unstable ware.

The three individual drives allow various stacking characteristics and motions to meet the production demands. The following motions are operated individually:

- Forward motion
- Side stroke motion
- Lifting of the stacker bar during return stroke

The actual stacking motion (contact to the glass) is executed by the combination of the forward and sideways movement.



The entire stacker is operated and monitored by the PLC in the main control panel. The graphic operator touch panel visualises the operational motions and settings. All special software such as „stop in front“, „offset stacking“, „slow motion when transferring to the lehr belt“ and others, are to be set at the operator screen on the main control panel.

In addition, the stacker is equipped with the function “Pre-calculation”. This function is an important assistance in order to pre-calculate the settings for a “new” production. The easy menu on the operator panel guides through the setting of parameters and provides information on status and error messages.

An automatic lubrication system is installed on this stacker, which minimizes service and maintenance. It consists of the electrically operated lubrication pump with a lubricant reservoir. The lubricant will be evenly distributed throughout the machine according to the Number of cycles executed. The control and monitoring of it is executed by the PLC.

However, even this stacker is equipped with the unique Pennekamp stacker bar cooling system. Therefore, it has a pressure controller installed at the back end in order to fine tune the stacker bar straightness during the production (on the run).

In addition, the stacker is prepared for the installation of a ware steady bar system that allows the support at the bottle finish during its forward stroke onto the lehr belt.

The start impulse may be connected as a potential free contact, generated from the ware transfer or coming from the forming machine. The start impulse may be shifted by use of an electrical differential gear (advance and retard).



Both movements are executed by separate servo drives. During the return stroke the third servo drive is responsible for lifting the stacker arm and respectively the stacker bar, to pass the finishes of the following row. In order to save time, it is set to minimum height requirement. This optimises time for the critical forward stroke.

The side stroke may be flexibly adjusted to a maximum of 700mm.

An internal cooling blower protects the enclosed stacker housing from overheating and/or being overheated by the hot air from the lehr. The enclosure (shielding) all around the stacker is made from stainless steel for cleanness.

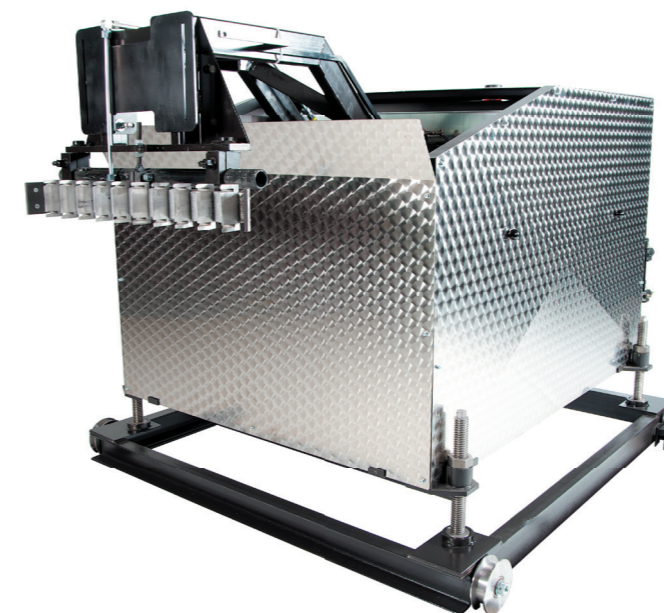

**Pressure fan**  
for cooling of machine



**Automatic lubrication system**  
for maintenance free operation

## Features

- Solid, electrical servo drive system by inverter (one for each motion)
- Electrical differential to advance or retard the start signal (synchronization)
- Most modern PLC control system with graphic human operator interface touch panel
- Automatic self set up calculation
- Adjustable stacking speeds and characteristics selectable by screen
- Electrical timing differential to advance/retard the start signal
- Automated lubrication system with electrical pump
- Rail/trolley system for stacker withdrawal
- Stacker bar air cooling system
- Operational mode „stop in front“
- Offset stacking

### Options:

- Steady bar system
- Air cooled pocket stacker bar
- Air cooled flat stacker bar

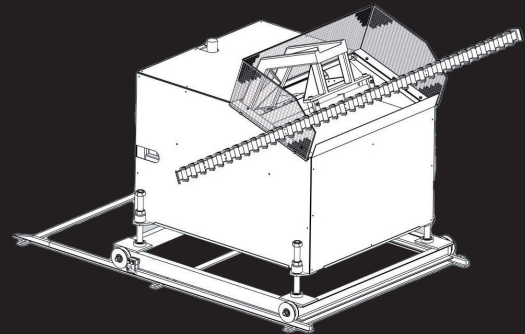
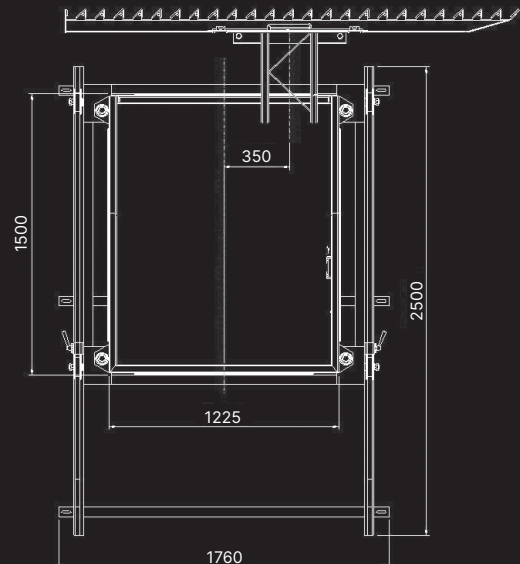

### 3-Axis Servo Stacker LS 750 / 3-AS

Lenght/Depth	1.500mm
Width	1.225mm
Height	1.150mm
Working height	850 - 1.070mm
Voltage	400V 50HZ*
Prefusing	10A
Compressed Air Pressure	2 - 6 bar 28 - 84 PSI
*others on request	

**pennekamp** ▶



Ernst Pennekamp GmbH & Co. OHG

Königsfelderstraße 38-42  
D-58256 Ennepetal

T +49 (0) 23 33 605 - 0  
info@pennekamp.de  
www.pennekamp.de